

Oil-supply systems

OWGD

Size 1 to 10

Assembly and operating instructions
BA 9702 en 03/2012

FLENDER supplies

SIEMENS

Oil-supply systems

OWGD
Size 1 to 10

Assembly and operating instructions

Translation of the original assembly and operating instructions

<u>Technical data</u>	1
<u>General notes</u>	2
<u>Safety instructions</u>	3
<u>Transport and storage</u>	4
<u>Technical description</u>	5
<u>Fitting</u>	6
<u>Start-up</u>	7
<u>Operation</u>	8
<u>Faults, causes and remedy</u>	9
<u>Maintenance and repair</u>	10
<u>Spare parts, customer service</u>	11
<u>Declarations</u>	12

Notes and symbols in these assembly and operating instructions

Note: The term "assembly and operating instructions" will in the following also be shortened to "instructions" or "manual".

Legal notes

Warning-note concept

This manual comprises notes which must be observed for your personal safety and for preventing material damage. Notes for your personal safety are marked with a warning triangle or an "Ex" symbol (when applying Directive 94/9/EC), those only for preventing material damage with a "STOP" sign.



WARNING! Imminent explosion!

The notes indicated by this symbol are given to prevent **explosion damage**.
Disregarding these notes may result in serious injury or death.



WARNING! Imminent personal injury!

The notes indicated by this symbol are given to prevent **personal injury**.
Disregarding these notes may result in serious injury or death.



WARNING! Imminent damage to the product!

The notes indicated by this symbol are given to prevent **damage to the product**.
Disregarding these notes may result in material damage.



NOTE!

The notes indicated by this symbol must be treated as general **operating information**.
Disregarding these notes may result in undesirable results or conditions.



WARNING! Hot surfaces!

The notes indicated by this symbol are made to prevent **risk of burns due to hot surfaces** and must always be observed.
Disregarding these notes may result in light or serious injury.

Where there is more than one hazard, the warning note for whichever hazard is the most serious is always used. If in a warning note a warning triangle is used to warn of possible personal injury, a warning of material damage may be added to the same warning note.

Qualified personnel

The product or system to which these instructions relate may be handled only by persons qualified for the work concerned and in accordance with the instructions relating to the work concerned, particularly the safety and warning notes contained in those instructions. Qualified personnel must be specially trained and have the experience necessary to recognise risks associated with these products or systems and to avoid possible hazards.

Intended use of Siemens products

Observe also the following:



Siemens products must be used only for the applications provided for in the catalogue and the relevant technical documentation. If products and components of other makes are used, they must be recommended or approved by Siemens. The faultfree, safe operation of the products calls for proper transport, proper storage, erection, assembly, installation, start-up, operation and maintenance. The permissible ambient conditions must be adhered to. Notes in the relevant documentations must be observed.

Trademarks

All designations indicated with the registered industrial property mark ® are registered trademarks of Siemens AG. Other designations used in these instructions may be trademarks the use of which by third parties for their own purposes may infringe holders' rights.

Exclusion of liability

We have checked the content of the instructions for compliance with the hard- and software described. Nevertheless, variances may occur, and so we can offer no warranty for complete agreement. The information given in these instructions is regularly checked, and any necessary corrections are included in subsequent editions.

Symbols

Earth connection point		Air relief point		yellow	
Oil-filling point		yellow	Oil-draining point		white
Oil level		red	Oil level		red
Oil level		red	Connection for vibration-monitoring device		
Lubrication point		red	Apply grease		
Lifting eye		Eye bolt			
Do not unscrew					
Alignment surface, horizontal		Alignment surface, vertical			

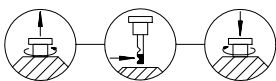

These symbols indicate the oil-level checking procedure using the oil dipstick.



These symbols indicate that the oil dipstick must always be firmly screwed in.

Contents

1.	Technical data	7
1.1	General technical data	7
1.2	Flow rates, dimensions, weights	8
1.3	Oil viscosity and oil type	8
1.4	Ambient conditions	8
1.5	Variant key	9
1.6	List of equipment	9
2.	General notes	10
2.1	Introduction	10
2.2	Copyright	10
3.	Safety instructions	11
3.1	Obligations of the user	11
3.2	Environmental protection	12
3.3	Special dangers and personal protective equipment	12
4.	Transport and storage	13
4.1	Scope of supply	13
4.2	Transport	13
4.3	Storage of the oil-supply system	14
4.4	Standard coating and preservation	15
5.	Technical description	16
5.1	General description	16
6.	Fitting	18
6.1	General information on fitting	18
6.1.1	Installation conditions	18
6.2	Check before start-up	19
6.3	General notes on add-on components	19
6.4	Final fitting work	19
7.	Start-up	20
7.1	Oil viscosity and oil type	20
7.2	Oil filling and changing oil	20
7.2.1	Flushing before initial start-up	20
7.2.2	Filling with oil for operation	21
7.3	Pump	21
7.4	Water oil-cooler	21
7.5	General notes on add-on components	22
7.5.1	Valve position of the shut-off valves and three-way valves	22
7.6	Removal from service	22
7.6.1	Interior preservation with preservative agent	23
7.6.2	Interior-preservation procedure	23

8.	Operation	24
8.1	General	24
8.2	Lubrication diagram	24
8.3	Control information	24
8.3.1	Three-way cock (7)	24
8.3.2	Pump (10, 13)	24
8.3.3	Filter (20)	24
8.3.4	Pressure gauge (45)	25
8.3.5	Pressure monitor (50, 55)	25
8.3.6	Thermometer (60)	25
8.3.7	Resistance thermometer (65)	25
8.3.8	Temperature monitor (70)	25
8.3.9	Volumetric-flow meter (80)	25
8.3.10	Cooling water flow regulator or magnetic valve as an option (see equipment list) (500)	25
8.4	Interlocking instructions	25
8.4.1	Pump enable	25
8.4.2	Gear unit enable	25
8.4.3	Warning	26
8.4.4	Gear unit stop	26
8.5	Response to malfunctions	26
8.6	Shut-down	26
9.	Faults, causes and remedy	27
9.1	General information on faults and malfunctions	27
9.2	Possible faults	27
9.2.1	Possible faults when installing the oil-supply system	29
9.2.2	Possible faults in maintenance	29
10.	Maintenance and repair	30
10.1	Oil viscosity and oil type	30
10.2	Replace defective pump	30
10.3	Replace water oil-cooler	31
10.4	Check or clean oil filter	31
10.5	Check hose lines	31
10.6	General notes on add-on components	31
10.7	Preservation	31
10.8	Cleaning	31
11.	Spare parts, customer service	32
11.1	Stocking spare parts	32
11.2	Addresses for ordering spare parts and customer service	32
12.	Declarations	33
12.1	Declaration of incorporation	33

1. Technical data

1.1 General technical data

The most important technical data on the oil-supply system are shown on the rating plate. These data and the contractual agreements between Siemens and the customer for the oil-supply system determine the limits of its correct use.

①		
②		
③	④	
⑤	⑥	⑦
⑧		⑨
⑩		
⑪		
⑫		
⑬		
14.3		⑭

Fig. 1: Oil supply system rating plate

- | | |
|---|---|
| <ul style="list-style-type: none"> ① Company logo ② Order number, item, sequence number, year built ③ Total weight in kg ④ Special information ⑤ Type ⑥ Size ⑦ Variant ⑧ $P_{Oil\ max}$ = max permissible oil operating overpressure | <ul style="list-style-type: none"> ⑨ t_{min} = minimum starting temperature ⑩ $P_{Water\ max}$... bar / ... PSI = permissible operating pressure of the water $t_{AMB\ max}$... °C / ... °F = maximum permissible ambient temperature ⑪ Instruction(s) number ⑫ Special information ⑬ Manufacturer and place of manufacture ⑭ Country of origin |
|---|---|

 These instructions generally include a list of equipment and drawings relating to the oil-supply system as well as the operating instructions relating to the accessory components (see table 2).

 Terminal box and wiring only if ordered.

Refer to table 1 for additional technical data.

1.2 Flow rates, dimensions, weights

Table 1: Flow rates, dimensions, weights

Size	Pump flow rate		Dimensions l x w x h mm	Weight kg
	50 Hz	60 Hz		
1	7	5.6	920x720x600	115
2	12	9.6	920x720x600	115
3	20	16	920x720x600	125
4	30	24	920x720x600	130
5	52	42	1140x975x775	250
6	75	60	1140x975x775	270
7	112	90	1400x990x925	405
8	150	120	1420x1175x1000	515
9	200	160	1620x1175x950	550
10	270	215	2320x1180x1070	785



All weights indicated apply for variant 4 without oil filling.

1.3 Oil viscosity and oil type

For the oil viscosity and oil type, refer to the gear-unit instructions manual and rating plate.

The oil-supply systems are designed for oil viscosities up to 5000 mm²/s at very low starting temperature (see rating plate ©).

1.4 Ambient conditions



The oil supply system may, unless otherwise agreed contractually, be used in an ambient temperature range of - 20 °C to + 40 °C and may not be exposed to any harmful environmental factors such as aggressive chemical products. Unless otherwise contractually agreed, the maximum permissible relative humidity is 55 % at 40 °C (= 28 g/m³).

The oil supply system must not be damaged by external radiation.

1.5 Variant key

Please refer to the following table to find the equipment of the oil-supply system according to the ordered variant (see also item 1.1).

Table 2: Variant key

List of equipment	Part no.	Variant				
		1	2	3	4	9
Base frame	1					
Three way cock, suction line	7					
2 pump groups, pressure-relief valve	10, 13					
Three-phase motor						
Double change-over filter	20					
Water oil-cooler	30					
2 non-return valves	35					
Pressure gauge	45					1)
Pressure monitor	50					1)
Pressure monitor	55					1)
Thermometer	60					1)
Resistance thermometer	65					1)
Temperature monitor	70					1)
Volumetric flow meter	80					1)
Cooling water flow regulator or magnetic valve as an option	500					1)
Terminal box and wiring only if ordered						

	not available
	available

1) as an option

1.6 List of equipment

In a separate list of equipment all parts are specified in accordance with the ordered variant and including the technical data.

2. General notes

2.1 Introduction

These instructions are an integral part of the delivery of the oil-supply system and must be kept in its vicinity for reference at all times.



All persons carrying out work on the oil-supply system must have read and understood these instructions and must adhere to them. Siemens accepts no responsibility for damage or disruption caused by disregard of these instructions.

The "**FLENDER oil-supply system**" dealt with in these instructions has been developed for cooling the oil and/or lubricating gear units. Possible areas of use for oil supply systems of this type include e.g. sewage treatment, excavators, the chemical industry, the iron and steel industry, conveyor systems, crane systems, the foodstuffs industry, paper machinery, cableways, the cement industry.

The oil-supply system is designed only for the application specified in section 1. "Technical data" and the list of equipment. Other operating conditions must be contractually agreed.

The oil-supply system has been manufactured in accordance with the state of the art and is delivered in a condition for safe and reliable use.

The oil-supply system may only be used and operated strictly in accordance with the conditions laid down in the contract governing performance and supply agreed by Siemens and the customer.

The oil-supply system described in these instructions reflects the state of technical development at the time these instructions went to print.

In the interest of technical progress we reserve the right to make changes to the individual assemblies and accessories which we regard as necessary to preserve their essential characteristics and improve their efficiency and safety.

2.2 Copyright

The copyright to these instructions is held by **Siemens AG**.

These instructions must not be wholly or partly reproduced for competitive purposes, used in any unauthorised way or made available to third parties without our agreement.

Technical enquiries should be addressed to the following works or to one of our customer service addresses:

Siemens AG
Am Industriepark 2
46562 Voerde

Tel.: +49 (0)2871 / 92-0
Fax: +49 (0)2871 / 92-1544

3. Safety instructions



In addition to this manual, the instructions manual relating to the gear unit must be observed.



**When entering the oil-supply system during operation and/or for maintenance and repair work, special care must be exercised.
Caution: risk of falling.**



Any changes on the part of the user are not permitted. This applies equally to safety features designed to prevent accidental contact.

- The cooling water temperature at the entrance to the cooler must be between + 4 °C and + 35 °C. Another maximum temperature is possible (see details in the list of equipment).

3.1 Obligations of the user

- The operator must ensure that everyone carrying out work on the oil-supply system has read and understood these instructions and is adhering to them in every point in order to:
 - avoid injury or damage to the user and third parties,
 - ensure the safety and reliability of the oil-supply system,
 - avoid disruptions and environmental damage through incorrect use.
- During transport, assembly, installation, demounting, operation and maintenance of the unit, the relevant safety and environmental regulations must be complied with at all times.
- The oil-supply system may only be operated, maintained and/or repaired by persons qualified for the work concerned (see "Qualified personnel" on page 3 of this manual).
- The gear unit must not be cleaned using high-pressure cleaning equipment.
- All work must be carried out with great care and with due regard to safety.
- Screwed pipe connections, flange connections and monitoring devices must not be loosened while the installation is under pressure. Pumps must be switched off and components under pressure must be eased beforehand.



Work on the oil-supply system may only be carried out when it is at a standstill. The drive unit must be secured against being switched on accidentally (e.g. by locking the key switch or removing the fuses from the power supply). A notice should be attached to the ON switch stating clearly that work on the oil-supply system is in progress.

The work specified in items 10.2 and 10.4 can also be carried out during operation, provided that the component is closed, pressureless and secured.



If any inexplicable changes are noticed during operation of the oil-supply system, such as a significant increase in temperature or unusual noises, the drive assembly must be stopped immediately.



Rotating and/or movable parts must be fitted with suitable safeguards to prevent contact.

- A potential equalisation in accordance with the applicable regulations and/or directives must be carried out!
If no threaded holes for earth connection are available on the oil-supply system, other appropriate measures must be taken. This work must always be done by **specialist electricians**.



The control instructions in section 8. "Operation" must always be observed.



The oil-supply system must be protected against falling objects.

If the oil-supply system is intended for mounting on plant or equipment, the manufacturer of such plant or equipment must ensure that the contents of the present instructions are incorporated in his own instructions.

- Removed safety equipment must be re-fitted prior to starting up.
- Notices attached to the oil-supply system, such as rating plate and direction arrow, must always be observed. They must be kept free from dirt and paint at all times. Missing plates must be replaced.
- Screws which have been damaged during assembly or disassembly work must be replaced with new ones of the same strength class and type.
- Spare parts must be obtained from Siemens (see section 11. "Spare parts, customer service").

3.2 Environmental protection

- Dispose of any packing material in accordance with regulations or separate it for recycling.
- When changing oil, the used oil must be collected in suitable containers. Any pools of oil which may have collected should be dealt with at once with an oil-binding agent.
- Preservative agents should be stored separately from used oil.
- Used oil, preservative agents, oil-binding agents and oil-soaked cloths must be disposed of in accordance with environmental legislation.
- Disposal of the oil-supply system after its useful life:
 - Drain all the operating oil, preservative agent and/or cooling agent from the oil-supply system and dispose of in accordance with regulations.
 - Depending on national regulations, oil-supply system components and/or add-on parts may have to be disposed of in different manners or be separated for recycling.

3.3 Special dangers and personal protective equipment



Depending on operating conditions, the surface of the gear unit and oil-supply system may heat up considerably.



With hot surfaces (> 55 °C) there is a risk of burns.



With cold surfaces (< 0 °C) there is a risk of frost injury (pain, numbness, frostbite).



During oil changes there is a risk of scalding from escaping oil.



**Small foreign matter such as sand or dust can get into the cover plates of the rotating parts and be thrown back by these.
Risk of eye injury.**



In addition to any generally prescribed personal safety equipment (such as safety shoes, safety clothing, helmet etc.), handling the gear unit requires wearing **suitable safety gloves** and **suitable safety glasses**.



The oil-supply system does not comply with the requirements in Directive 94/9/EC and must therefore, in the area of applicability of this directive, not be used in potentially explosive areas.

Caution, danger to life.

Should the oil-supply system unit be used outside the area of applicability of Directive 94/9/EC within potentially explosive areas, the nationally applying protective prescriptions with regard to explosion protection must always be observed.

4. Transport and storage

Observe the instructions in section 3. "Safety instructions"!

4.1 Scope of supply

The products supplied are listed in the dispatch papers. Check immediately on receipt to ensure that all the products listed have actually been delivered. Parts damaged and/or missing parts must be reported to Siemens in writing immediately.



If there is any visible damage, the oil-supply system must not be put into operation.

4.2 Transport



**When handling these products, use only lifting and handling equipment of sufficient load-bearing capacity.
Observe the notes regarding load distribution on the packing.**

The oil-supply system is delivered in a fully assembled condition. Additional items are delivered separately packaged, if applicable. Depending upon the individual application, the gear unit can also be assembled with the oil-supply system and delivered with it as an assembled unit.

Different forms of packaging may be used depending on the size of the oil-supply system or assembled unit and method of transport. Unless otherwise agreed, the packaging complies with the **HPE Packaging Guidelines**.

The symbols marked on the packing must be observed at all times. These have the following meanings:

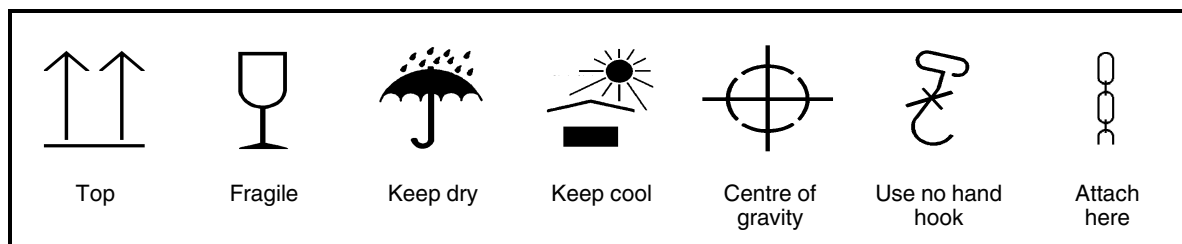

Fig. 2: Transport symbols



The oil-supply system or assembled unit must always be transported so as to avoid injury to persons and damage to the unit.



During transport the oil-supply system should be left without oil filling and on the transport packaging.



To transport and handle gear units with attached oil-supply systems, use only the lifting eyes specially provided for this purpose on the gear units. The position of the attachment points is shown in the documentation of the gear unit for each specific order.



**When handling the separate oil-supply system, exercise special care to avoid damage due to the use of force or careless loading and unloading.
To transport and handle the oil-supply system, use ropes or chains. Only the designated lifting eyes on the base frame may be used for fastening.
Care must be taken that the carrier ropes do not damage fittings and pipework. A cross-beam is therefore required for protection. The lengths of the ropes must be set to ensure that the base frame is suspended horizontally.**

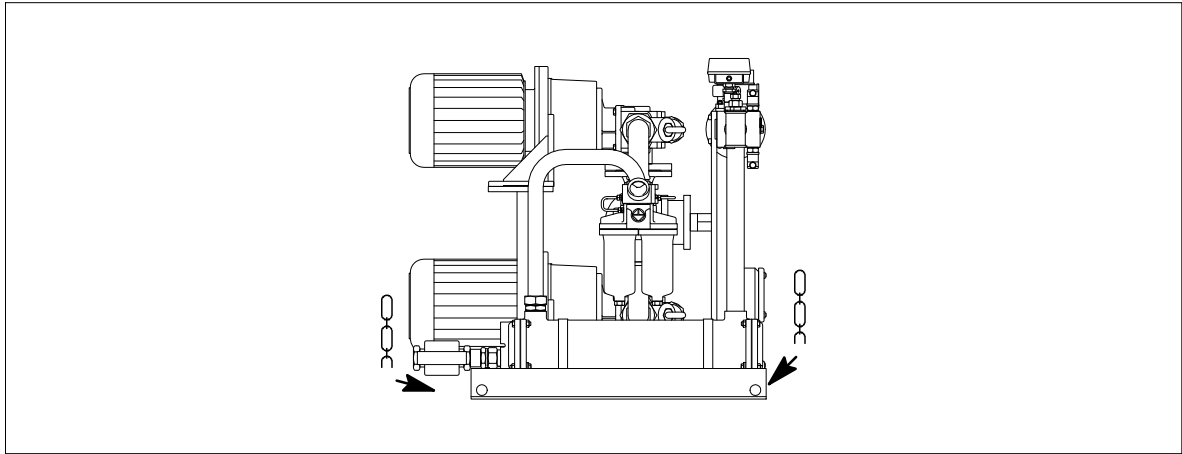

Fig. 3: Attachment points



For a detailed illustration of the oil-supply system and the position of the attachment points, please refer to the drawings in the documentation of the oil-supply system.

4.3 Storage of the oil-supply system

The oil-supply system or unit must be stored in a sheltered place in the position of the original packaging or in the position of use, placed on a vibration-free, dry base, and covered over.



When temporarily storing the oil-supply system or units, and any single components supplied with it, the preservative agent should be left on them. It must not be damaged, otherwise there is a risk of corrosion.



Do not stack oil-supply systems or assembled units one on top of another.



If the oil-supply system or assembled unit is being stored out of doors, it must be very carefully covered over and care must be taken that neither moisture nor foreign material can collect on the unit. Waterlogging should be avoided.



Provision for special environmental conditions during transport (e.g. transport by ship) and storage (climate, termites, etc.) must be contractually agreed.



All pipe openings must be sealed with plugs or flanged covers.

4.4 Standard coating and preservation

The oil-supply system is provided with an interior preservation.

The characteristics of the external coat depend on the ambient conditions stipulated in the order relating to method of transport and area of application.



Oil-supply systems are normally delivered completely finished, with a priming and finish coat.

Where oil-supply systems are delivered with a priming coat only, it is necessary to apply a finish coat in accordance with directives applying to the specific case. The priming coat alone is not suitable to provide a sufficient long-term corrosion protection.



Ensure that the coat is not damaged.

Any damage may cause failure of the exterior protective coating and corrosion.



Unless otherwise contractually agreed, the interior preservation is guaranteed for 6 months, provided that storage is in dry, frost-free sheds.

The guarantee period starts on the date of delivery or that of the notification that the item is ready for shipment.

For a longer period of storage (> 6 months) the interior preservation must be renewed (see section 7. "Start-up").

5. Technical description

Observe the instructions in section 3. "Safety instructions"!

5.1 General description

The "**FLENDER oil-supply system**" described in this manual has been designed for cooling oil and/or lubricating a gear unit (see section 1. "Technical data").



Before starting up, the monitoring devices must in all cases be connected as specified in the separate interlocking instructions.

- The oil supply is ensured by two batteries of pumps, of which one battery serves as a spare pump.
- The pump sucks the oil out of the gear-unit oil sump via a suction pipe.
- A filter is installed in the oil circuit to filter the circulating oil.
- Heat generated by losses and not removable by convection is removed via a water oil-cooler.
- Filtered and re-cooled oil is then resupplied to the gear unit via a pressure line.
- The above described components are fitted on a base frame of the oil-supply system.



For control instructions, refer to section 8. "Operation".

Observe for this the drawings and the list of equipment. The components specified in the list of equipment can also be found on the drawings with the part number.

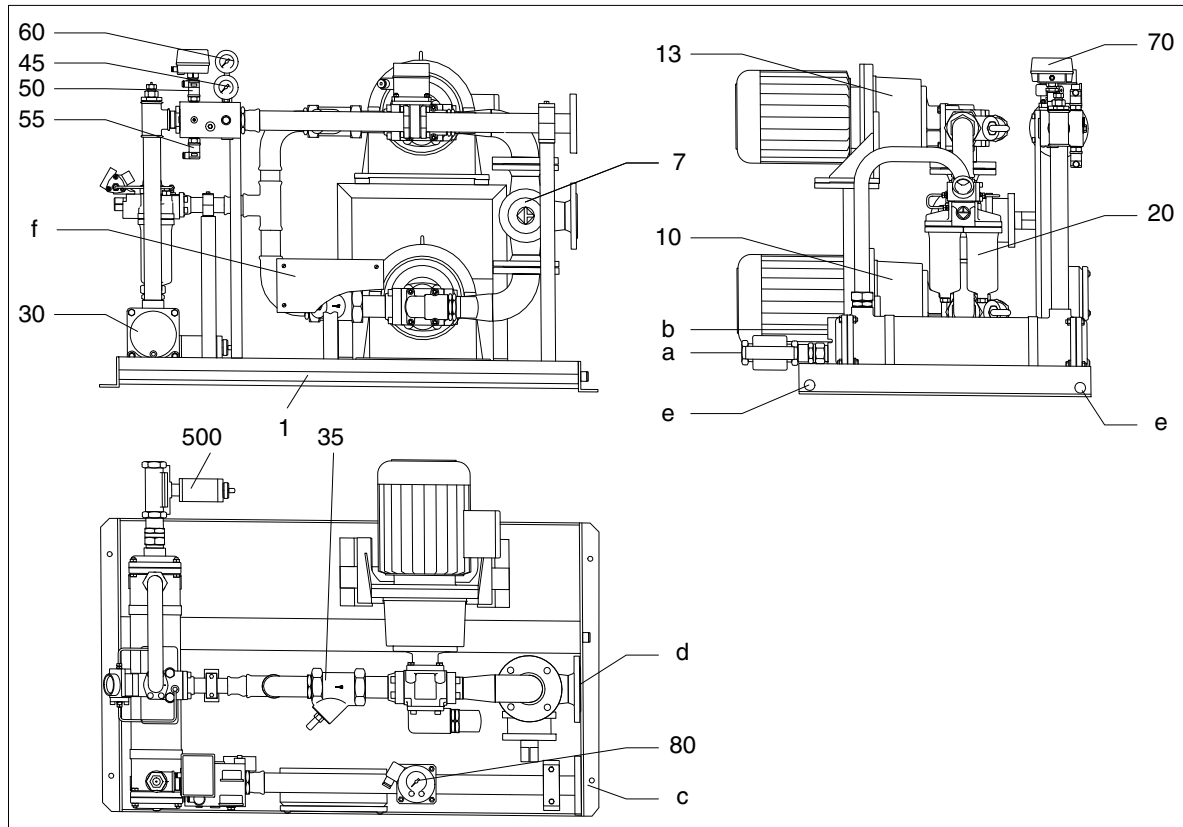

Fig. 4: Equipping the oil supply system of size 7 in variant 4

- | | | | |
|----|-----------------------------------|-----|--------------------------------|
| 1 | Base frame | 55 | Pressure monitor |
| 7 | Three way cock | 60 | Thermometer |
| 10 | Pump group, pressure-relief valve | 70 | Temperature monitor |
| 13 | Pump group, pressure-relief valve | 80 | Volumetric-flow meter |
| 20 | Double change-over filter | 500 | Cooling-water flow regulator |
| 30 | Water oil-cooler | a | Cooling water inlet |
| 35 | Non-return valve | b | Cooling water outlet |
| 45 | Pressure gauge | c | Pressure connection |
| 50 | Pressure monitor | d | Suction connection |
| | | e | Lifting eyes |
| | | f | Terminal box (only if ordered) |



A detailed view of the oil supply system can be obtained from the drawings in the oil supply unit documentation.



The direction of discharge of the pump used is dependent upon the direction of rotation.

The direction of rotation of the motors must correspond to the direction of the arrow on the pump.



To ensure optimum cooling performance, the specified direction of flow in the water oil-cooler must be observed. The cooling-water inlet and outlet must not be reversed. The pressure of the cooling water must not exceed 8 bar.

It is necessary to check whether the quality of the cooling water is adequate for operation with regard to the materials of the cooler which are used (see information in equipment list) and that the cooler is not damaged by this.

The cooling water should not contain any solid components. Particles must not be greater than 0.1 mm.

If there is a danger of freezing, the cooling water must be drained off. Remove any remaining water with compressed air.



Be especially careful when blowing with compressed air. Wear protective glasses.

6. Fitting

Observe the instructions in section 3. "Safety instructions"!

6.1 General information on fitting

All preserved flange surfaces must be washed with a suitable solvent.



Environmental protection requirements must be observed.

- If connection pipes are not supplied with the system, seamlessly drawn and bright normalised (NBK) pipes of at least P 235 TR 2 in accordance with DIN 2391 c (hydraulic tubing, quality grade C) must be used.
- The interfaces must be provided with the appropriate flanges or screw connections.
- For connection pipes we recommend using compensators to insulate against vibration and compensate for stretching.
- Pipe fastenings (plastic clips) must be used to install pipework. The distance between 2 clips must be less than 2 m / 78.7".
- Make sure the pipework is not twisted.
- Welded pipes must be pickled before fitting them.
- After installation the pipes must be flushed out.
- The motors and monitoring equipment must be connected up electrically in accordance with terminal diagrams, lists of equipment and regulations. Check voltage and circuits.
- Before connecting the water oil-cooler, remove the sockets from the cooling-water connection and flush the water oil-cooler well to remove any dirt.
- Install the cooling-water in- and outflow pipes. For the flow direction of the cooling water and the location of the connections please refer to the dimensioned drawing.
- The plugs and flange covers must be removed and the separately supplied fittings fitted to the system in accordance with the lubrication plan and drawings (see section 8. "Operation").
- Separately supplied parts with a screw connection must be carefully cleaned and sealed with LOCTITE 128068.

6.1.1 Installation conditions

When planning space utilisation (e.g. implementation of plans by the customer) care must be taken that there is sufficient space available around the oil-supply system for fitting and repair work to be carried out without obstruction.



The load-bearing capacity of the lifting gear installed must be sufficient. (For details on the oil-supply system, refer to section 1. "Technical data").

The oil-supply system must be installed on a level, secure and rigid foundation or foundation frame. Care must be taken that the oil can be drained and an adequate air supply for the motors is provided. The fittings and the wearing parts must be easily accessible and checking them must be possible.

The permissible deviation of the standing surface of the oil-supply system from the horizontal plane is 2 mm per 1 m (0.08" per 40"); if necessary use compensation plates.

6.2 Check before start-up

- Observe the data on the rating plate.
- Check that voltage and frequency of the motor correspond to the mains-supply values.
- Check that the motor is properly protected.
- Check that the electrical connections are properly tightened and the monitoring equipment is properly connected and set.
- Check that air-inlet holes and cooling surfaces are clean.
- A potential equalisation in accordance with the applicable regulations and/or directives must be carried out.
If no threaded holes for earth connection are available on the oil-supply system, other appropriate measures must be taken. This work must always be done by **specialist electricians**.
- Check that the terminal-box cover is closed and the pipework inlets are properly sealed.



Connections must be carried out by a specialist in accordance with the current safety regulations. The relevant installation and operating requirements and the usual national and international regulations must be observed.

6.3 General notes on add-on components



For operation and maintenance of the components specified in the list of equipment, observe the specified operating instructions.
For technical data, refer to the list of equipment.

6.4 Final fitting work

Once the oil-supply system has been installed, all pipework, all screw connections and flanges must be retightened, particularly suction pipes (to avoid inadmissible air intake). Leaks must be resealed.



Fit necessary safety equipment.



The oil-supply systems as well as the adjacent pipework must be protected against falling objects.

7. Start-up

Observe the instructions in section 3. "Safety instructions"!



During start-up, all required instructions (oil-supply system, gear unit and add-on components) must be available. The oil-supply system must not be started up without the required instructions being available.



If there is any visible damage, the oil-supply system must not be put into operation.



In all cases oil must be put in before starting up.

Shut-off valves must be secured against unintentional closing.



Unless otherwise contractually agreed, aids and/or devices for securing the stop valves against unintentional opening and closing are not included in the scope of delivery of Siemens.

All impurities must be removed from the oil-supply system before starting up and after repair and maintenance work. This applies particularly to water (e.g. rainwater) to prevent an oil-water mixture.



All pumps, filters and coolers must be vented.



Pressure-relief valve and/or safety valve pressure settings made by Siemens at its works must not be altered, as they are not used to control the pressure and the flow rate. They serve only as a protection against overload.

7.1 Oil viscosity and oil type



For the oil viscosity and oil type, refer to the gear-unit instructions manual and rating plate.

The oil-supply systems are designed for oil viscosities up to 5000 mm²/s at very low starting temperature (see rating plate ⑨).

7.2 Oil filling and changing oil



For oil-change intervals and the description of the oil-change procedure, refer to the gear-unit instructions manual.

7.2.1 Flushing before initial start-up

To remove preservative-agent residues, which could cause the oil to foam, the oil-supply system must be flushed out together with the gear unit before starting up. The following procedure should be adhered to for flushing:

- Fill with oil (see gear-unit instructions).



After filling, the filling holes must be correctly closed and sealed.

- Operate the oil-supply system for 30 minutes (while the gear unit is stationary).
- Replace filter elements (while the system is stationary and pressureless).



Observe the instructions relating to the filter.

- Drain flushing oil (see item "Changing the oil" in the gear-unit instructions manual).



The flushing oil must be carefully drained out of the oil-supply system, the monitoring equipment and the oil chambers in the gear unit, while it is warm. It may be re-used only as flushing oil. The flushing oil must be cleaned before re-use.



There is a danger of scalding from the hot oil emerging from the housing. Wear protective gloves.



Any oil spillage must be dealt with immediately with an oil-binding agent.

7.2.2 Filling with oil for operation



Before starting up the gear unit and/or the oil-supply system, oil must be put in.

The oil filling of the oil-supply system is done by way of the gear unit. Filling is possible using an auxiliary oil pump. Care must be taken that no dirt can get into the oil circuit. Oil must be poured in until it is level with the specified oil level on the oil-level indicator (see gear-unit instructions). The oil must be poured in while the pump is stationary. The pump can then be started.

Before starting up the gear unit for the first time, the oil-supply system must be run for at least 15 minutes to fill all the oil chambers (see instructions manual for gear unit). Then shut down the oil-supply system and, if necessary, correct the oil level.

All pipework - particularly suction pipes (inadmissible air intake) - as well as all screw connections and flanges must be retightened. Leaks must be resealed.



For the valve positions of the three-way valves, refer to table 3 (see item 7.5.1 "Valve position of the shut-off valves and three-way valves").

7.3 Pump



The direction of discharge of the pump used is dependent upon the direction of rotation.

The direction of rotation of the motors must correspond to the direction of the arrow on the pump.



As regards the pump, the specific operating instructions of the manufacturer must be observed.

7.4 Water oil-cooler

The necessary water connections for the water oil-cooler must be provided for by the customer/operator.



To ensure optimum cooling performance, the specified direction of flow in the water oil-cooler must be observed. The cooling-water inlet and outlet must not be reversed. The pressure of the cooling water must not exceed 8 bar.

It is necessary to check whether the quality of the cooling water is adequate for operation with regard to the materials of the cooler which are used (see information in equipment list) and that the cooler is not damaged by this.

The cooling water should not contain any solid components. Particles must not be greater than 0.1 mm.

If there is a danger of freezing, the cooling water must be drained off. Remove any remaining water with compressed air.



Be especially careful when blowing with compressed air. Wear protective glasses.



As regards the water oil-cooler, the specific operating instructions of the manufacturer must be observed.

7.5 General notes on add-on components



For operation and maintenance of the components specified in the list of equipment, observe the specified operating instructions.
For technical data, refer to the list of equipment.

7.5.1 Valve position of the shut-off valves and three-way valves

Table 3: Valve positions

Process step	Part number 7	Part number 20
Filling	Middle position	Middle position
Draining	Middle position	Middle position
Operation	Middle position	Flow only to active filter chamber
Inactive pump replacement	Flow only to active pump	Flow only to active filter chamber

Definitions relating to table 3:

- Middle position = All pathways are open
- Flow-through only to... = Flow-through to active part is open, to inactive part is closed

7.6 Removal from service

- Switch off oil-supply system.



Secure the oil-supply system to prevent it from being started up unintentionally. Attach a warning notice to the start switch.

- Close the stop valves in the cooling-water in- and outflow pipes.
- Drain cooling water. Remove any remaining water with compressed air.



Be especially careful when blowing with compressed air. Wear protective glasses.

7.6.1 Interior preservation with preservative agent

Oil-supply systems for pressure lubrication should be run idle with preservative agent prior to any long-term storage.

Table 4: Preservation procedure when using mineral oil or PAO-based synthetic oil

Duration of protection	Preservative agent	Special measures
Up to 6 months	Castrol Alpha SP 220 S	None
Up to 24 months		Close connection pipes
For storage periods longer than 24 months the oil-supply system must be re-preserved.		

Table 5: Preservation procedure when using PG-based synthetic oil

Duration of protection	Preservative agent	Special measures
Up to 6 months	Special anti-corrosion oil TRIBOL 1390 ¹⁾	None
Up to 36 months		Close connection pipes
For storage periods longer than 36 months, Siemens should be consulted beforehand.		

1) Resistant to tropical conditions and sea water; maximum ambient temperature 50 °C

7.6.2 Interior-preservation procedure

- Remove the oil-supply system from service and drain off the oil.
- Fill in preservative agent in accordance with table 4 or 5 (if necessary, via the connected gear unit).
- Start the oil-supply system and allow it to idle for a short time (15 minutes).
- Drain off the preservative agent into a suitable receptacle and dispose of the oil in accordance with the regulations.



There is a risk of scalding from the hot preservative agent draining from the gear unit. Wear protective gloves.

8. Operation

Observe the instructions in section 3. "Safety instructions", in section 9. "Faults, causes and remedy" and in section 10. "Maintenance and repair"!



The oil-supply systems as well as the adjacent pipework must be protected against falling objects.

8.1 General



The oil-supply system should be operated alternately (interval period 1 week) by pump 1 and pump 2 in order to guarantee even wear. The pump that is not in operation serves then as a spare pump.

For the pressure monitors and the volumetric-flow monitor a delay time of 10 seconds should be provided.

After switching off the main drive, the oil-supply system must continue to run until the drive has come to a complete standstill.

8.2 Lubrication diagram



For the drawing number of the relevant lubrication diagram, refer to the list of equipment.

8.3 Control information

The part numbers (...) given in the following text have been taken from the list of equipment, assembly drawing and the lubrication diagram.

The following control information and/or locking instructions must be noted for the individual components:



In addition to this control information and/or locking instructions, the specifications in the list of equipment must always be observed.

Only the control information and/or interlocking instructions of the parts shown in the list of equipment apply to the delivered oil-supply system. For the specific switch points and/or values, refer to the list of equipment.



Further control information and/or locking instructions are given in the instructions manual of the gear unit.



For the valve positions of the shut-off valves and three-way valves, refer to table 3 (see item 7.5.1 "Valve position of the shut-off valves and three-way valves").

8.3.1 Three-way cock (7)

A three-way cock is provided on the suction side. When exchanging a pump this serves for shutting off the suction line for this pump with simultaneous operation of the spare pump. In normal operation the three-way cock must be set so as to ensure that the suction lines are open to both pumps.

8.3.2 Pump (10, 13)

When the pump is operating, the system pressure is limited by a pressure-relief valve integrated into the pump.



The factory setting of this valve must not be changed.

8.3.3 Filter (20)

The filter is monitored visually by means of a differential-pressure indicator and electrically by means of a differential-pressure monitor.

8.3.4 Pressure gauge (45)

The oil pressure is indicated visually by means of a pressure gauge.

8.3.5 Pressure monitor (50, 55)

The pressure in the oil-supply system is monitored by means of a pressure monitor.

8.3.6 Thermometer (60)

The oil temperature is indicated visually by means of a thermometer.

8.3.7 Resistance thermometer (65)

The temperature monitoring of the system occurs with a resistance thermometer or optionally with a resistance thermometer with a transmitter (see equipment list). The transmitter sends an output signal proportional to the oil temperature.

8.3.8 Temperature monitor (70)

The temperature of the system is monitored by means of a temperature monitor.

8.3.9 Volumetric-flow meter (80)

The oil flow is monitored by means of a volumetric-flow meter.

8.3.10 Cooling water flow regulator or magnetic valve as an option (see equipment list) (500)

The cooling water flow is regulated to suit the required cooling performance.

8.4 Interlocking instructions



When enabling and determining starting condition for pumps, it must be ensured that temperature values are based on VG 320 mineral oil.
If other oils are used, the viscosity of the oil for that temperature value must not be higher.

8.4.1 Pump enable

PUMP ENABLE when the following condition is fulfilled:

Oil temperature < temperature value (65.1)

Oil temperature < switch point (70.1)

8.4.2 Gear unit enable

GEAR UNIT ENABLE is given when the following conditions are fulfilled:

Filter differential pressure < switch point (20)

Oil pressure > switch point (55)

Oil temperature < temperature value (65.1)

Oil temperature < switch point (70.1)

Oil flow quantity > switch point (80.1)

Run-up time of oil-supply system at least 2 minutes (in case of circulating oil lubrication).

8.4.3 Warning

WARNING is given when one of the following conditions is fulfilled:

Differential pressure of filter	> switch point (20) after a time span of 30 seconds
Oil pressure	< switch point (55) = SPARE PUMP ON
Oil temperature	> temperature value (65.1)
Oil temperature	> switch point (70.1)
Oil flow quantity	< switch point (80.1)

8.4.4 Gear unit stop

GEAR UNIT STOP is given when one of the following conditions is fulfilled:

Oil pressure	< switch point (50)
Oil temperature	> temperature value (65.2)
Oil temperature	> switch point (70.2)
Oil flow quantity	< switch point (80.2)

If, when **GEAR UNIT STOP** occurs, the oil temperature is > temperature value (65.2) or optionally > switch point (70.2), the pump must be set to remain on up to an oil temperature of < temperature value (65.1) or < switch point (70.1).

8.5 Response to malfunctions



Irrespective of the following information, the local safety requirements will apply in all cases for operation of the oil-supply system.

Monitoring during operation is essential to identify any malfunctions occurring (see section 9. "Faults, causes and remedies") and thus to implement preventive measures. The operating pressures and oil temperatures should be recorded regularly.

If irregularities at variance with the normal condition are noticed during operation, or if the operating data change, the cause must be identified immediately. If necessary, shut the system off. If the causes cannot be identified, even with the aid of the Troubleshooting List, inform Siemens at once (see section 2. "General notes").



For restart after malfunction, the information in section 7. "Start-up" should be noted.

8.6 Shut-down

If the gear unit and oil-supply system are shut down for longer periods (> 4 weeks), the following measures are necessary:

- Gear unit and oil-supply system remain filled with oil.
Every 4 weeks the gear unit and oil-supply system must be run for 1 hour. The necessary pre-lubrication and post-lubrication times should be observed.
- If the measures listed under a) are not possible, the gear unit and the oil-supply system must be preserved (see section 7. "Start-up").



If there is a danger of freezing, the cooling water must be drained off. Remove any remaining water with compressed air.



Be especially careful when blowing with compressed air. Wear protective glasses.

9. Faults, causes and remedy

Observe the instructions in section 3. "Safety instructions" and in section 10. "Maintenance and repair"!

9.1 General information on faults and malfunctions



Faults and malfunctions occurring during the guarantee period and requiring repair work on the oil-supply system must be carried out only by Siemens Customer Service. If faults and malfunctions occur after the guarantee period, the cause of which cannot be precisely identified, we advise our customers to contact our customer service.



Siemens will not be bound by the terms of the guarantee or warranty or otherwise be responsible in cases of improper use of the oil-supply system, modifications on the oil-supply system carried out without the agreement of Siemens, or use of spare parts not supplied by Siemens.



**For remedying faults and malfunctions, the oil-supply system must always be taken out of service.
Secure the drive unit to prevent it from being started up unintentionally.
A notice should be attached to the ON switch stating clearly that work on the oil-supply system is in progress.**

9.2 Possible faults

Table 6: Faults, causes and remedy

Faults	Causes	Remedy
Oil temperature too high.	No cooling water. Insufficient cooling water. Cooling water too warm. Air in cooler. Cooler fouled up.	Rectify cooling-water supply. Increase cooling-water supply. Vent the cooler. Remove pipe assembly and clean water oil-cooler and pipe assembly or replace with new pipe assembly. See separate instructions manual.
Oil temperature too low.	Gear unit has not yet heated up. Too much cooling water. Cooling water too cold.	Wait. Reduce cooling-water supply.

Faults	Causes	Remedy
Oil pressure too low.	<p>Filter is clogged.</p> <p>Pressure relief valve incorrectly set.</p> <p>Pressure relief valve damaged.</p> <p>Suction line is clogged.</p> <p>Pump is drawing in air.</p> <p>Oil temperature too high.</p> <p>Oil viscosity too low.</p> <p>Pump damaged, pump drive damaged.</p>	<p>Switch filter over to clean filter and clean or replace filter element. See separate instructions manual.</p> <p>Contact Siemens.</p> <p>Repair and / or replace pressure relief valve. See separate instructions manual.</p> <p>Clean suction line.</p> <p>Check suction line and repair any leaks.</p> <p>see there.</p> <p>Check oil viscosity. Fill with correct oil if necessary.</p> <p>Switch pump over to spare pump and repair defective pump and/or replace it. See separate instructions manual.</p>
Oil pressure too high.	<p>Gear unit has not yet heated up.</p> <p>Pressure relief valve incorrectly set.</p> <p>Pressure relief valve damaged.</p> <p>Oil pipes to and on gear unit are clogged.</p> <p>Oil viscosity too high.</p>	<p>Wait.</p> <p>Contact Siemens.</p> <p>Repair and / or replace pressure relief valve. See separate instructions manual.</p> <p>Find and clean the clogged line.</p> <p>Check oil viscosity. Fill with correct oil if necessary.</p>

Faults	Causes	Remedy
Unusual or increased filter residues.	Filter contaminated. Pipes contaminated (Scale, welding residues). Abraded material from gear unit. Oil contaminated. Abraded material from defective pump.	Clean or replace filter. Clean the pipes. Gear unit Check (bearings, teeth, alignment) and repair defects. Change oil. Switch pump over to spare pump and repair defective pump and/or replace it. See separate instructions manual.
Oil consumption too high.	Leak in pipes, connections, valves or gear unit. Shaft outlets on gear unit leaky. Cooler leaky. Filter leaky.	Tighten screws. Reseal. Replace sealing rings. Seal cooler and/or replace cooler insert. See separate instructions manual. Seal filter.

9.2.1 Possible faults when installing the oil-supply system

- Important information for describing the drive and the environment are not communicated.
- Performance data too high.
- Cooling water not available or contaminated.
- Chemically aggressive environment not taken into consideration.
- The ambient temperature is not permissible.
- Components with transport or other damage are being fitted.
- Loosely supplied parts are interchanged.
- Specified tightening torques are not being adhered to.
- Operating conditions are being changed without authorisation.

9.2.2 Possible faults in maintenance

- Maintenance intervals are not being adhered to.
- Leakage in the vicinity of the oil-supply system is not being identified and as a result chemically aggressive media are damaging the oil-supply system.

10. Maintenance and repair

Observe the instructions in section 3. "Safety instructions" and in section 9. "Faults, causes and remedy"!



The oil-supply systems as well as the adjacent pipework must be protected against falling objects.



The work specified in items 10.2 and 10.4 can also be carried out during operation, provided that the component is closed, pressureless and secured.

10.1 Oil viscosity and oil type

For the oil viscosity and oil type, refer to the gear-unit instructions manual and rating plate.

The oil-supply systems are designed for oil viscosities up to 5000 mm²/s at very low starting temperature (see rating plate ⑨).



For oil-change intervals and the description of the oil-change procedure, refer to the gear-unit instructions manual.

10.2 Replace defective pump



The valve settings of the shut-off valves and three-way valves specified in table 3 (see item 7.5.1 "Valve position of the shut-off valves and three-way valves") must be adhered to.

The valves must be secured against unintentional opening and closing.

Observe the instructions relating to the pump.

- Set valve opening "replace inactive pump" (see table 3).
- Release pressure from pump.
 - To do so, carefully undo the breather screw on the pump or on the pump flange and unscrew.
- Drain oil from the pump and the pipework.
- Remove the pump.
- Install the new or repaired pump.
- Screw the breather screw into the pump or pump flange.
- Set valve opening "operation" (see table 3).
- Bleed the pump.
 - To do so, carefully undo the breather screw on the pump or on the pump flange and wait until the operating fluid emerges.
- Once the operating fluid has emerged, screw the breather screw in leak-tightly.

10.3 Replace water oil-cooler



Observe the instructions relating to the water oil-cooler.

- Stop the oil-supply system.
- Release pressure from the cooler.
 - To do so, carefully undo the breather screws on the cooler and unscrew.
- Drain oil from the cooler and the pipework.
- Drain water from the cooler and the pipework.
- Remove the cooler.
- Fit the new or repaired cooler.
- Screw the breather screws back into the cooler.
- Start the oil-supply system.
- Vent the cooler.
 - To do so, carefully undo the breather screw on the cooler and wait until the operating fluid emerges.
- Once the operating fluid has emerged, screw the breather screw in leak-tightly.

10.4 Check or clean oil filter



For a description of the procedure of cleaning and/or changing the filter, refer to the filter instructions manual.

10.5 Check hose lines

Even when adequately stored and subjected to permissible loads, hoses and hose lines are subject to a natural ageing process. This limits their period of use.



The period of use of the hose lines must not exceed 6 years from the manufacturing date stamped on them.

The period of use can be determined using available test and empirical values, taking into account the conditions of use.



The operator of the system must ensure that hose lines are replaced at suitable intervals of time, even if no defects which may affect their safe operation are identifiable on them.

Hose lines must be inspected for safe working condition by an expert before the plant is first put into operation and thereafter at least once a year.



If a fault is found during an inspection, this must be rectified immediately or suitable countermeasures taken.

10.6 General notes on add-on components



For operation and maintenance of the components specified in the list of equipment, observe the specified operating instructions.
For technical data, refer to the list of equipment.

10.7 Preservation

Refer to section 7. "Start-up" and section 8. "Operation".

10.8 Cleaning



To prevent the build-up of dust on the oil-supply system, cleaning must be done in accordance with the local operating conditions.

The oil-supply system must not be cleaned with high-pressure cleaning equipment.

11. Spare parts, customer service

11.1 Stocking spare parts

By stocking the most important spare and wearing parts on site you can ensure that the oil-supply system is ready for use at any time.



Siemens guarantee only the original spare parts supplied by Siemens. Non-original spare parts have not been tested or approved by Siemens. They may alter technical characteristics of the oil-supply system, thereby posing an active and/or passive risk to safety. Siemens will assume no liability or guarantee for damage caused by spare parts not supplied by Siemens. The same applies to any accessories not supplied by Siemens.

Please note that certain components often have special production and supply specifications and that Siemens supplies you with spare parts which comply fully with the current state of technical development as well as current legislation.

To order spare parts, refer to the list of equipment.

When ordering spare parts, always state the following:

Material number of the oil-supply system

Production order

Part number

Quantity

11.2 Addresses for ordering spare parts and customer service

When ordering spare parts or requesting a service specialist, please contact Siemens first (see section 2. "General notes").

12. Declarations

12.1 Declaration of incorporation

Declaration of incorporation

in accordance with Directive 2006/42/EC, Annex II 1 B

The manufacturer, Siemens AG, 46395 Bocholt, Germany, declares with regard to the partly completed machinery

Oil-supply systems OWGD Size 1 to 10

for cooling oil and/or lubricating gear units:

- The special technical documents described in Annex VII B have been prepared.
- The following basic health and safety requirements set out in Directive 2006/42/EC, Annex I, are applied and are satisfied:
1.1, 1.1.2, 1.1.3, 1.1.5; 1.2.2, 1.2.4.4; 1.3.1 - 1.3.4, 1.3.6, 1.3.7; 1.4.1, 1.4.2.1;
1.5.1 - 1.5.11, 1.5.13, 1.5.15; 1.6.1 - 1.6.4; 1.7.1, 1.7.1.1, 1.7.2, 1.7.3 - 1.7.4.3
- The partly completed machinery must not be put into service until it has been established that the machinery into which the partly completed machinery is to be incorporated has been declared to be in conformity with the provisions of Directive 2006/42/EC, as appropriate.
- The partly completed machinery is in conformity with the provisions of the Directive(s):
94/9/EC
- The manufacturer undertakes, in response to a reasoned request by the national authorities, to transmit in electronic form relevant information about the partly completed machinery.
- The person authorised to compile the relevant technical documentation is:
Dr. Nico van de Sandt (Head of Engineering DAE)

Voerde, 2012-03-28

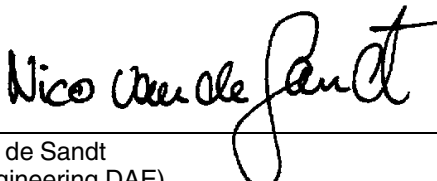

Dr. Nico van de Sandt
(Head of Engineering DAE)

Voerde, 2012-03-28



Dr. Bernhard Hoffmann
(Vice-President Business Subsegment DA)

Further Information:

"FLENDER gear units" on the Internet

www.siemens.com/gearunits

"FLENDER couplings" on the Internet

www.siemens.com/couplings

Service & Support:

<http://support.automation.siemens.com/WW/view/en/10803928/133300>

Lubricants:

<http://support.automation.siemens.com/WW/view/en/42961591/133000>

Siemens AG
Industry Sector
Mechanical Drives
Alfred-Flender-Straße 77
46395 Bocholt
GERMANY

Subject to modifications

© Siemens AG 2012

www.siemens.com/drive-technologies