

AERZEN

SCREW COMPRESSORS

Aerzen Screw Compressors VMY .56 for the refrigeration- and process gas industry



AERZEN

AERZENER MASCHINENFABRIK
GMBH

V1-040 | 00 | EN

2000 9.2008



VMY .56, screw compressors of the Aerzener Maschinenfabrik especially designed for operation in the refrigeration industry.



Aerzener Maschinenfabrik was founded in 1864. In 1868, Aerzen produced Europe's very first rotary piston machine designed according to the Roots principle. The manufacture of rotary piston gas meters began in 1930, followed by the instruction of the first rotary screw compressor in 1943.

Experience in the production of twin shaft rotary lobe machines is also reflected in quality assurance. Since 1990, Aerzener Maschinenfabrik counts itself among the manufacturers whose quality assurance has been certified acc. to ISO 9001, world-wide.

Dedicated to constant technological progress, Aerzen has evolved into a modern enterprise and a world leader in the field of specialized machine engineering. The steady growth of our staff, presently counting over 1000 experienced engineers, technicians and craftsmen ensures Aerzen's leading position.

The excellence of Aerzen's sales and service organization is recognized around the world.

As pioneer of the German engineering branch of industry the Aerzener Maschinenfabrik started the development of screw compressors in the thirties.

By constant further development and application of most modern technology the Aerzener Maschinenfabrik succeeded in belonging to today's market leader in the range of oil-free and oil-injected compressors for nearly all gases.

Since the beginning of the production of VMY screw compressors more than 5500 screw compressors have been delivered for refrigeration in the foodstuff industry, pharmaceutical industry, chemical and petrochemical industry, for refrigeration on ships as well as heat pumps and as expander for energetic recovery of dissipated heat.





VMY .56, the new generation of refrigeration compressors made by Aerzener Maschinenfabrik, stands for an efficient performance adaptation.

Advantages VMY series 56*

1. Especially developed bearings:

The especially robust bearings consist of four radial slide bearings and four angular contact ball bearings. The driven rotor has a balancing piston for reduction of the axially occurring gas forces. The axial bearings are separated by intermediate discs, so that every axial bearing separately can be supplied with fresh oil. This type of bearings has been taken over especially based on our experiences for decades in process gas technology and guarantees long bearing lifetimes, allowing nominal lifetimes of the axial bearings of 100.000 hours and more under standard refrigeration technical conditions with ammonia.

2. Oil supply:

The compressor has a main oil connection via which the bearings, the mechanical seal and the balancing piston can be supplied through internal oil channels. This leads to reduced piping expenditure as well as less leakage possibilities.

The main oil consumers such as mechanical seal, bearings and balancing piston are supplied by a flanged-on gear wheel oil pump. Consequently oil supply of the moved components is guaranteed permanently while the compressor is in operation.

3. Rotors:

In case of male rotor drive the rotors are made of forged steel and in case of female rotor drive made of surface-hardened special steel and designed for long lifetimes. The 4 + 6 profile for female rotor drive developed by Aerzener Maschinenfabrik distinguishes itself by a high reliability. The first rotors made of this material and with this drive system on the female rotor side are now working for more than twelve years. This reliability of the rotor profile made us count on the female rotor drive also in future.

4. Vi setting:

The VMY 56 series is equipped with a manual Vi, being steplessly adjustable between 2,2 and 5,0. Consequently e.g. summer-/winter operation can be run without any problems and without having to realize an expensive control system. Or in case of optimal absorbed power at coupling the stage can be used as Swing machine. Optionally an automatic Vi is also available.

5. Economizer:

The compressor has two Economizer connections, which guarantee an optimal filling of the chamber and as a result reduce the operation costs.

6. Special suction-sided inlet contour:

By means of the development of a special suction-sided inlet contour the inflow conditions could be improved in order to guarantee an optimal COP.

7. Housing material:

As standard the housing is made of high-quality material EN-GJS-400-18-LT (GGG 40.3).

8. Capacity slide valve lubrication:

Specially drilled bores between the housing and the capacity slide valve arrange for lubrication of the capacity slide valve. Thus the wear in this area is reduced to an absolute minimum, in order to guarantee a long lifetime of the compressor.

9. Increased safety:

On the compressor a measuring point for the oil pressure has been provided. This always guarantees, that the compressor is supplied with oil sufficiently. This considerably contributes to the increase of the plant safety.

10. Robust displacement sensor:

The displacement sensor being easy to calibrate was especially developed for screw compressors.

*concerning VMY 056 deviating bearings



VMY .56 offers a concept of economy, environmental attention and flexibility; slide valve or speed control as well as regulation of the internal pressure ratio are just examples.

Operational lifetime and costs

The newly designed rotor profile – another step in development of the existing 4+6 D-Profile – as well as the bearing quality, consequently tested for long lifetime (up to 100.000 hours), prolongate maintenance periods and lower operational costs. An optimal operating safety is guaranteed by a flanged oil pump for lubrication of the compressor.

Quality

Now that decades of experience in the manufacture of compressors have been connected with the latest concepts of production and development a refrigeration compressor has been designed that can be operated with all refrigerants presently known. With its certified quality Aerezner Maschinenfabrik is always prepared to meet the customer's particular demands.

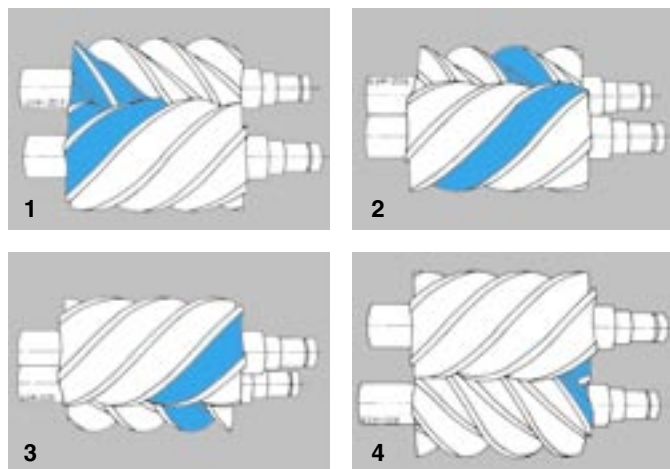

1 Intake

Gas enters through the gas intake aperture and flows into the helical grooves of the rotors which are open at the intake side.

2 and 3 Compression process

As rotation of the rotors proceeds, the gas intake aperture closes, oil is injected, the volume diminishes and pressure rises.

4 Discharge

The compression process is completed, the final pressure attained, the discharge commences.

Compressor size

Depending on the compressor size a modular system of equipment is available so that the customer's requirements can be met exactly.

As both, male and female rotor drive can be chosen any required conveying volume flow can be achieved on a well-tested serial machine.

No costly and complicated case to case developments have to be made.

Smooth operation, Low noise

No pending masses influence the operation of these machines. All moving parts are rotating and have been dynamically balanced so that no free inertia forces occur.

The noise level has been minimized by means of absolutely suitable wall thicknesses and axial outlet area.

Economy, environmental safety and flexibility

Slide valve or speed control, as well as regulation of the internal pressure ratio, those are the catchwords for a concept of economy, environmental safety and flexibility.



Picture 1: R717 -6°C/+35°C / VMY 256 MHR



VMY .56 are used for a various range of applications, e.g. from low temperatures, air conditioning plants to refrigeration plants on ships.



Picture 2: R717 -25°C/+35°C / VMY 256 MNR



Picture 3: R717 -6°C/+30°C / VMY 256 MNR



Picture 4: R717 2°C/+37°C / VMY 256 MHR driven via frequency converter



VMY .56 a large number of refrigerants can be used:

Refrigerants free from halo: R 717 (NH₃), methane, ethane, propane, butane, propene. Halo carbons: R 22, R 134a, R 507, R 404a

Performance data NH₃

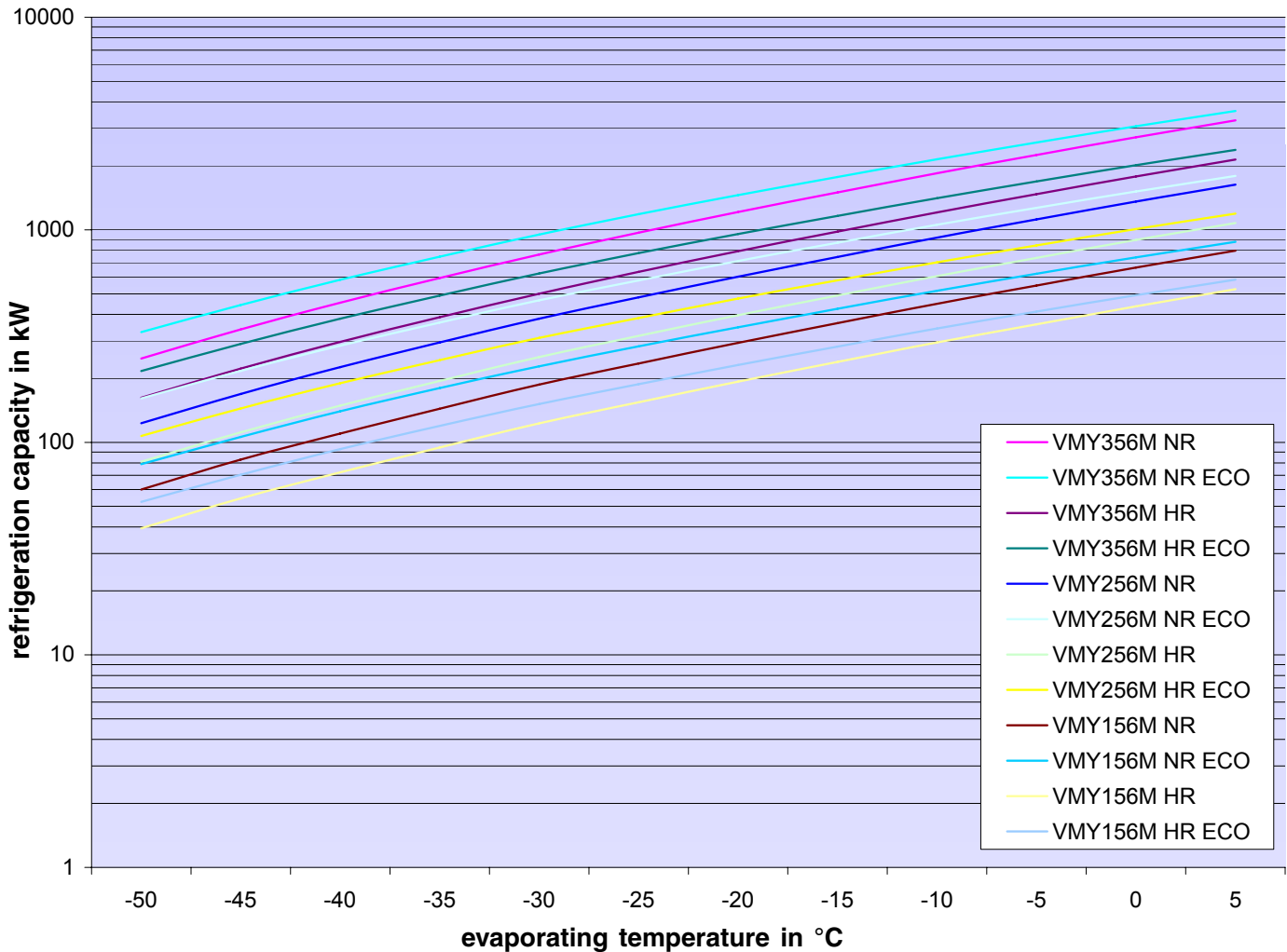

VMY 156 to VMY 356

longitudinal section vertical

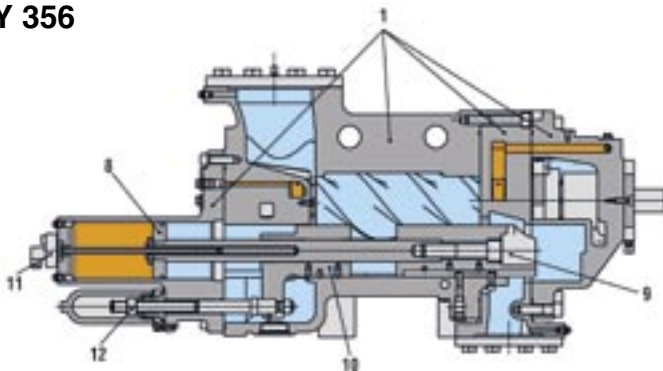

longitudinal section horizontal

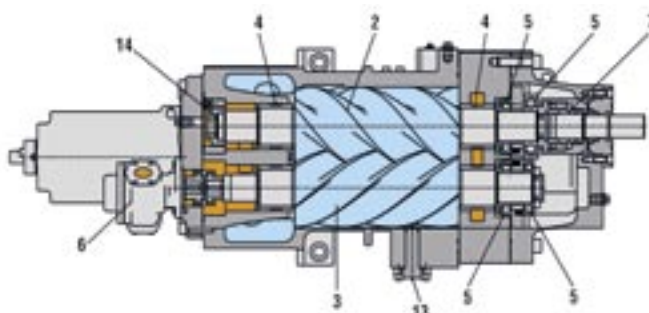

- 1 housing
- 2 male rotor
- 3 female rotor
- 4 radial bearing
- 5 axial bearing
- 6 oil pump
- 7 mechanical seal
- 8 hydraulic piston capacity control
- 9 slide valve
- 10 V₁-slide
- 11 transsonar displacement sensor
- 12 V₁-control
- 13 ECO-connection
- 14 balance piston



VMY .56 is available in 3 sizes. Alternative use of the male or female rotor drive makes it possible to achieve 6 different intake volumes.

Technical data

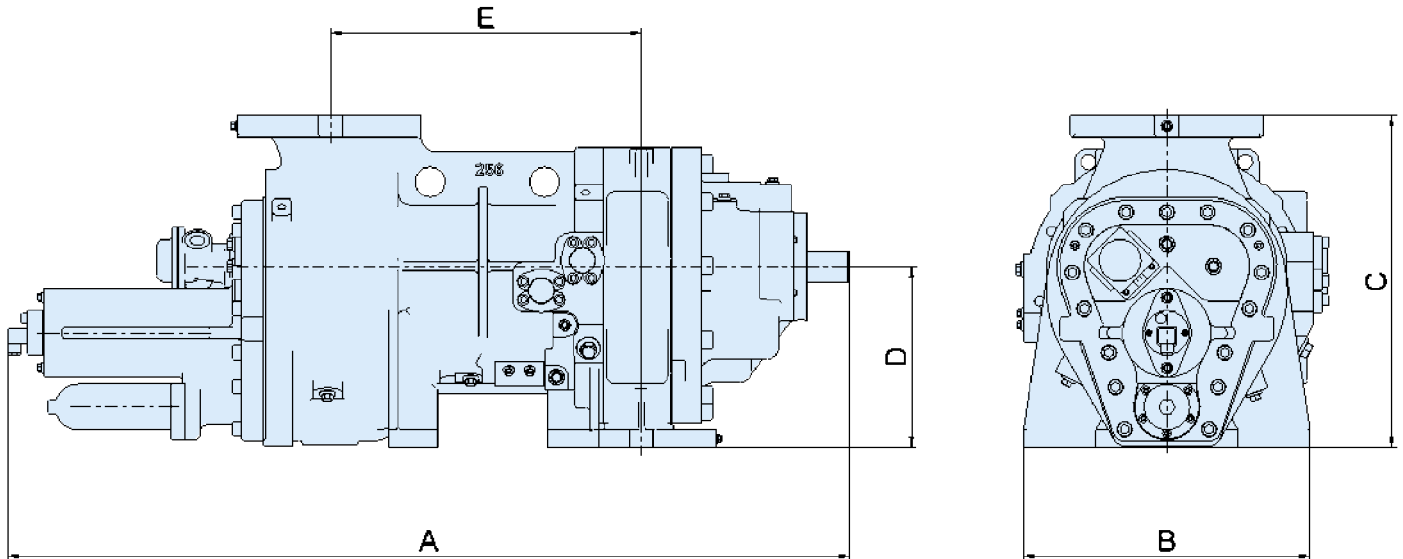

			VMY 156 M		VMY 256 M		VMY 356 M	
			HR	NR	HR	NR	HR	NR
L/D		-	2,1	2,1	2,1	2,1	2,1	2,1
Intake volume 3000 RPM		m ³ /h	444	678	911	1378	1809	2708
A		mm	1160		1395		1730	
B		mm	390		475		560	
C		mm	445		550		645	
D		mm	250		300		355	
E		mm	420		516		648	
Flange gas-intake	Nominal width	mm / inc	100 / 4		150 / 6		200 / 8	
	Pressure range	bar g	40		40		40	
Flange gas-discharge	Nominal width	mm / inc	50 / 2		100 / 4		100 / 4	
	Pressure range	bar g	40		40		40	
V _i - control		-	2,2 - 5,0 (continuously adjustable)					
Weight		kg	370		660		1100	

All dimensions for information only and without responsibility!

Subject to technical changes!

HR = male rotor, NR = female rotor

A good address, everywhere

Federal Republic of Germany

Aerzener Maschinenfabrik GmbH · Reherweg 28
31855 Aerzen / Germany
Tel. + 49 51 54 8 10
Fax + 49 51 54 8 11 91

Vertriebsbüro Nord
Weißer Kamp 23
29683 Bad Fallingbommel
Germany
Tel. + 49 51 62 98 13-0
Fax + 49 51 62 98 13 20

Vertriebsbüro Ost
Klosterstraße 8-9,
13581 Berlin / Germany
Tel. + 49 30 36 75 84-6
Fax + 49 30 36 75 84 80

Außenstelle Taucha:
August-Bebel-Str. 13c
04425 Taucha / Germany
Tel. + 49 34 29 81 46 86
Fax + 49 34 29 81 46 87

Vertriebsbüro Mitte
Erfurter Straße 2
63796 Kahl / Germany
Tel. + 49 61 88 91 04-0
Fax + 49 61 88 91 04 20

Vertriebsbüro Süd
Föhrenweg 1
89275 Elchingen / Germany
Tel. + 49 73 08 96 08-0
Fax + 49 73 08 96 08 20

Vertriebsbüro West
Taubenstraße 12
42551 Velbert / Germany
Tel. + 49 20 51 98 54-0
Fax + 49 20 51 98 54 18

Außenstelle Nahlbach
Meisenweg 13
66809 Nahlbach / Germany
Tel. + 49 68 38 89 95 95
Fax + 49 68 38 89 58 78

Europe

Aerzen-France S.A.S.
10, Avenue Léon Harmel
92168 Antony Cedex
France
Tel. + 33 1-46 74 13 00
Fax + 33 1-46 66 00 61
for France, Algeria, Morocco and Tunisia

Aerzen Machines Ltd.
Aerzen House, Langston Road
Loughton, Essex, IG 103 SL
United Kingdom
Tel. + 44 20 85 02 81 00
Fax + 44 20 85 02 81 02

Aerzen Belgium NV
Zone Guldendelle
A. De Coninckstraat 11
3070 Kortenberg / Belgium
Tel. + 32 2-7 57 22 78
Fax + 32 2-7 57 22 83
for Belgium and Luxembourg

Aerzen Nederland B.V.
Fotograaf 3
6921 RR Duiven
The Netherlands
Tel. + 31 26-311-26 41
Fax + 31 26-311-73 69

Aerzen Iberica S.A.
c/Urogallo 13
28946 Fuenlabrada / Spain
Tel. + 34 91-6 42 44 50
Fax + 34 91-6 42 29 03

Aerzen Iberica S.A.
Rua: Sacadura Cabral, 216, 7º B
2765-349 S. João do Estoril
Portugal
Tel. + 35 12 14 68 24 66
Fax + 35 12 14 68 24 67

Aerzen Svenska AB
Östra Bangatan 20
19560 Arlandastad
Sweden
Tel. + 46 8-59 12 21 90
Fax + 46 8-59 11 72 09

Aerzen Finland Oy AB
Teollisuustie 15
02880 Veikkola / Finland
Tel. + 35 89 - 8 19 47 20
Fax + 35 89-4 77 22 25

Bran & Luebbe AS
Sandviksveien 22
1363 Høvik / Norway
Tel. + 47 67 83 26 50
Fax + 47 67 83 26 51
for Norway and Iceland

Aerzen Svenska AB
Nakskovvej 28
2500 Valby / Denmark
Tel. + 45 36 16 40 48
Fax + 45 36 16 40 48

Aerzen Austria
Handelsges. m.b.H.
Gewerbepark Tresdorf II/1
2111 Tresdorf / Austria
Tel. + 43 22 62 7 43 88
Fax + 43 22 62 7 43 99

Aerzen (Schweiz) AG
Zürcherstrasse 300
8500 Frauenfeld
Switzerland
Tel. + 41 52-7 25 00 60
Fax + 41 52-7 25 00 66
for Switzerland and Liechtenstein

Aerzen Italia SRL
Via Vittor Pisani, 28
20124 Milano / Italy
Tel. + 39 02-67 07 52 77
Fax + 39 02-67 07 50 03

MANGRINOX S.A.
14, Grevenon Str.
11855 Athens / Greece
Tel. + 30 210-3 42 32 01-3
Fax + 30 210-3 45 97 67

Aerzen Makine Sanayi Ve Ticaret Ltd. Sti.
Yukari Dudullu Bostancı Yolu
Cad. Keyap Sitesi A-2 Blok No:12
34775 Ümraniye - Istanbul
Turkey
Tel. + 90 420 00 32
Fax + 90 420 00 79

Aerzen Polska S.A.
Ul. Marconich 9/17
02-954 Warszawa / Poland
Tel. + 48 22 642 29 09
Fax + 48 22 642 33 08

Aerzen Slovakia S.R.O.
Mariánska 17
90031 Stupava / Slovakia
Tel. + 42 12 65 93 46 94
Fax + 42 12 65 45 71 01

Aerzen Hungária Kft.
Bécsi út 52.III./4.
1036 Budapest / Hungary
Tel. + 36 14 39 22 00
Fax + 36 14 39 19 22

Aerzen Cz s.r.o.
Namesti TGM 729/7
69002 Breclav
Czech Republic
Tel. + 42 05 19 32 66 57
Fax + 42 05 19 32 66 58

HAFI Engineering & Consulting Gesellschaft m.b.H.
Mühletorplatz 4-6
6800 Feldkirch / Austria
Tel. + 43 55 22-7 79 24-0
Fax + 43 55 22-7 49 38
for the remaining countries in Eastern Europe

Brasil, Mexico, USA, Canada and Asia

Aerzen do Brasil Ltda.
Rua Howard Archibaldi
Acheson Jr. N° 615
Jardim da Glória, Cep 06711
280 Cotia, SP / Brasil
Tel. + 55 11-46 12 40 21
Fax + 55 11-46 12 02 32

Aerzen México
Av. San Rafael 31
Fraccionamiento Industrial
Lerma
Lerma 52000 Estado de México (Toluca) / México
Tel. + 52 72 82 82 55 08
Fax + 52 72 82 82 51 97

Aerzen USA Corporation
645 Sands Court
Coatesville, PA 19320 / USA
Tel. + 1 610-3 80 02 44
Fax + 1 610-3 80 02 78

Aerzen Canada Blowers Compressors Inc.
1995 Montée Labossière
Vaudreuil, Quebec J7V8P2
Canada
Tel. + 1 450-4 24-39 66
Fax + 1 450-4 24-39 85

Aerzen Asia Pte. Ltd.
38 Woodlands
Industrial Park E1
#04-01 Singapore 757700
Tel. + 65 6254 5080
Fax + 65 6254 6935

Aerzen International Trading (Shanghai) Co. Ltd.
No. 519 Tong Li Road
Jiu Ting Town
Song Jiang District
201615 Shanghai / P.R.China
Tel. + 86 21 5109 7767
Fax + 86 21 5109 7768

Aerzen Machines (India) Private Limited
301-1 A Square Building
82-Urmi Society
Productivity Road
Vadodara - 390007 / India
Tel. + 91 265 2324306
Tel. & Fax + 91 265 2324307

We would be pleased to provide the addresses of our representatives in the remaining continents, upon request.



Aerzener Maschinenfabrik GmbH

Reherweg 28 · 31855 Aerzen / Germany – P.O. Box 1163 · 31849 Aerzen / Germany
Phone + 49 51 54 / 8 10 · Fax + 49 51 54 / 8 11 91 · www.aerzen.com · info@aerzener.de